

Part Number	Size	"R"	"O"	"H"	"S" MIN	"L"
5233746	1 1/4	7.250	1.000	3.625	2.000	3.81
5233748	2	9.500	1.250	4.750	3.125	5.00
5233750	3	13.000	1.750	6.500	3.250	6.81
5233751	3 1/2	15.000	2.000	7.563	3.375	7.88
5233776	4	16.000	2.063	8.000	3.625	8.38
5233753	5	27.000	3.188	12.000	3.750	12.56
5233754	6	30.000	4.000	15.000	6.625	15.69

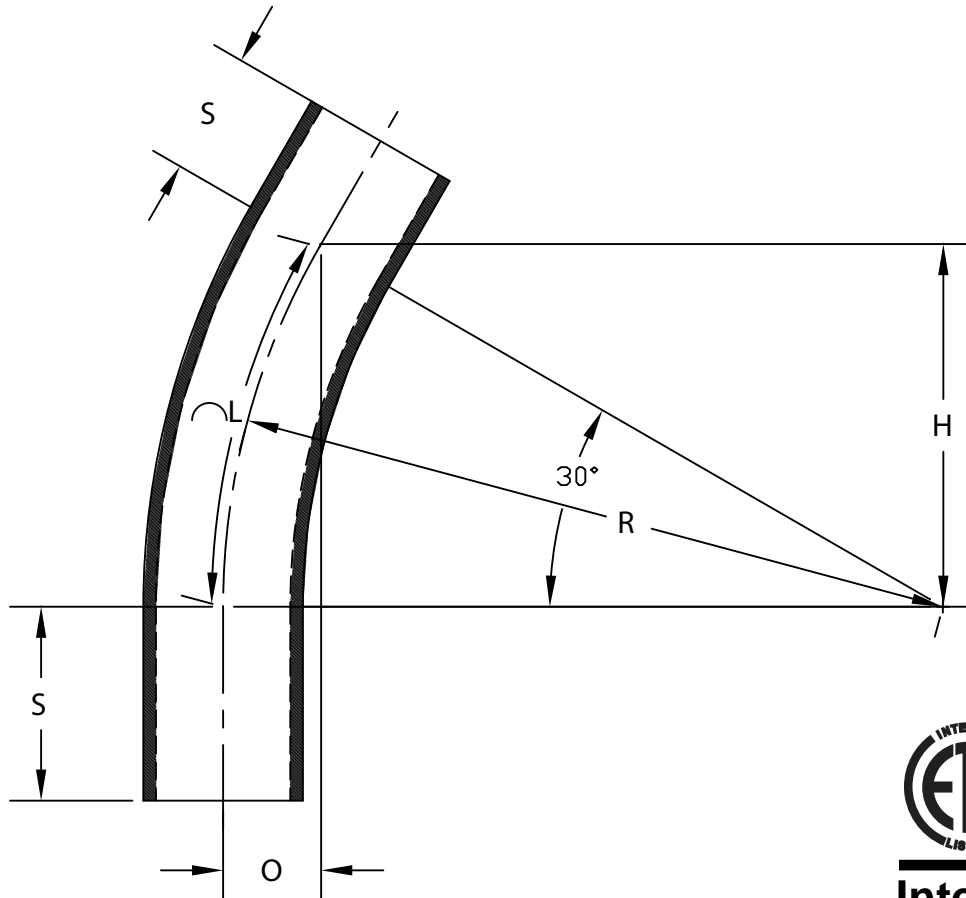

ETL LISTED  
 CONFORMS TO UL651  
 ETL CONTROL #3107144  
 CONFORMS TO NEMA TC3  
 SEE NEC ARTICLE 352 FOR USE  
 MATERIAL IS RIGID PVC  
 BEND TOLERANCE IS  $\pm 2^\circ$   
 "B" TOLERANCE IS  $-\frac{1}{8}"$ ,  $+\frac{1}{2}"$



**CANTEX**  
 INC.  
 Fort Worth, Texas

30° Elbow Plain End  
 Schedule 40 Standard Radius

Drawn By: CD Branch

Date: 10/15/07

Ref.